



HUBER

Grab Screen TrashLift

Cable operated coarse screen for the protection of:

- ▶ Pumping stations
- ▶ Seawater intake systems
- ▶ Water power plants
- ▶ Large sewage treatment plants

More information,
downloads and
current news



Installation

The HUBER Grab Screen TrashLift combines the sturdy installation of coarse screening with reliable and proven crane technology. The combination of load winch (1) and steel cable is characterised by its high adaptability to a wide range of channel widths and channel depths.

Impurities and screenings are retained at the grate section (5) and removed by a tray gripper (3). The tray gripper has been designed for an optimised stripping process and is also characterised by its high discharge capacity. The weight of the bucket gripper and coarse screenings is borne by the load winch.

During the upward movement of the cleaning process, the tray with the removed screenings is guided along the chute plates (4) and safely cleaned at the upper end point by a scraper (2). A control winch (6) at the header of the machine opens and closes the bucket.

MBR Package Plant capacity

- ▶ Channel width up to 4 m.
Wider on request.
- ▶ Discharge height above channel floor: up to 30 m.
Deeper on request.
- ▶ Bar spacings: ≥ 16 mm
- ▶ Possible installation angles: 70 – 90°
- ▶ Grate length up to 10 m
- ▶ Longer on request
- ▶ EX variant available

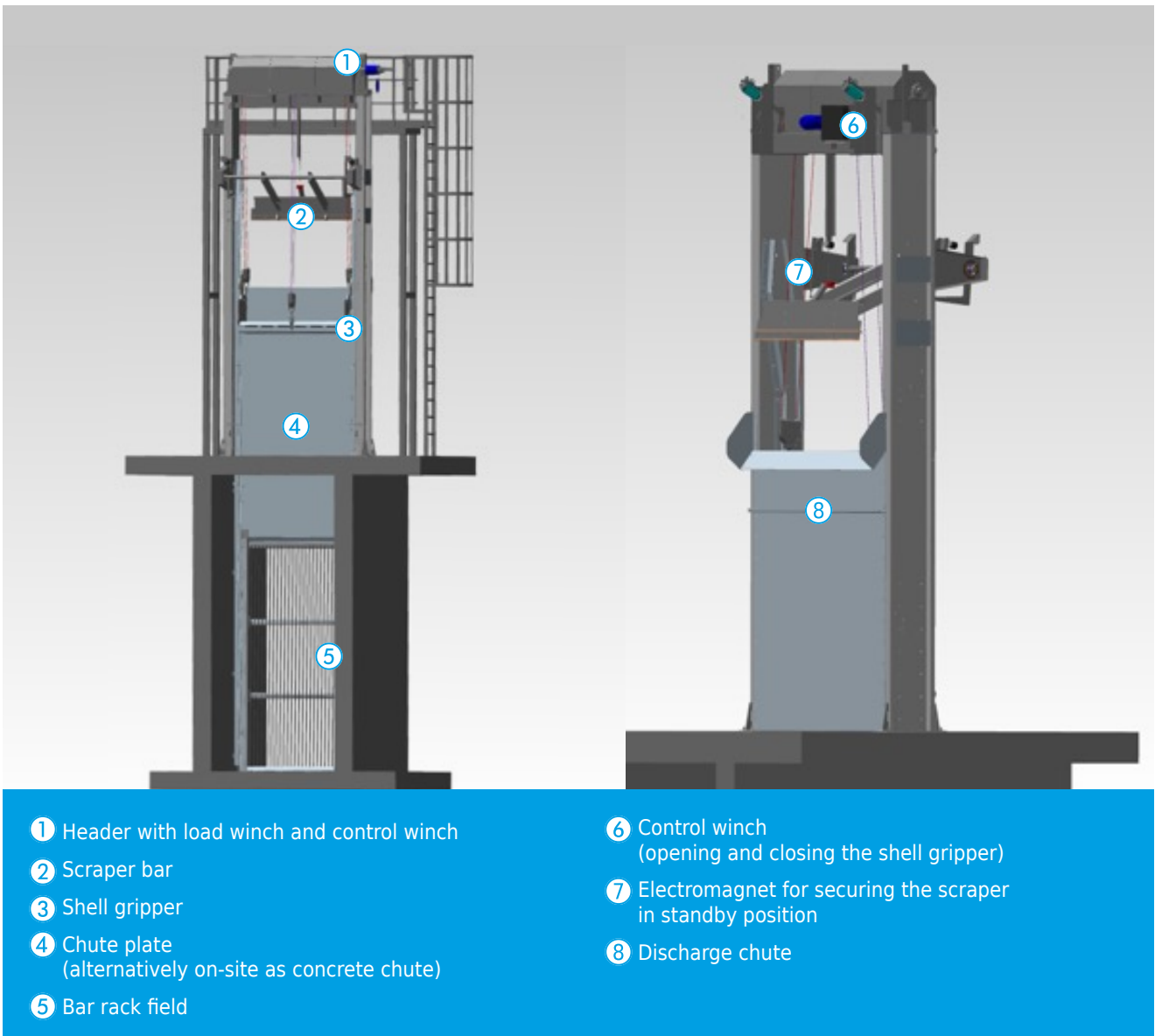

HUBER Grab Screen TrashLift, machine design on the inlet side (Fig. left), machine design on the outlet side (Fig. right).

Design and function

The unscreened water flows through the trash rack and the coarse debris contained in the flow are retained on the grate area. As a result of the occupancy of the grate area, there is a difference in level before and after the screen over time. The cleaning cycle starts once a predefined limit value is exceeded. The grate area is cleaned cyclically by the shell gripper, which moves close to the bottom when open and then closes by actuating the control winch. As a result of its own weight, the tray gripper exerts a certain contact pressure on the grate. Since only the dead weight is used, serious consequential damage due to wedging of stones or similar is minimised. The weight of the shell and coarse screenings is borne (in the upward movement) by the load winch. In the upward movement, the tray with the removed screenings is guided along the chute plates until it reaches the scraper. The scraper is moved to the discharge position by releasing an electromagnet. As soon as the scraper is in position, the tray gripper continues to move upwards and uses the scraper to discharge screenings and impurities. After discharge of impurities and screenings, the scraper is locked in its standby position by activating the electromagnet, the grab opens again and moves to the waiting position for the next operation. During travel through the grate field and discharge area, the load winch runs at low speed, in downward travel and at high speed over the chute plates, which results in minimising cleaning time and optimising cleaning cycles per hour.

Benefits of the HUBER Grab Screen TrashLift

- ▶ 90° installation, thus minimum system diameter
- ▶ Reliable removal of bulky material with high operating reliability
- ▶ High capacity grab with replaceable rake teeth
- ▶ Near-bottom removal of channel debris
- ▶ Operation of the grab cleaner without rope deflections, ensuring maximum rope service life
- ▶ Low maintenance cost, as only one load winch and one control winch are required
- ▶ Optimised cleaning speed and cleaning cycles per hour thanks to reduced travel speeds in the discharge area and grate section as well as increased travel speed over the chute plates

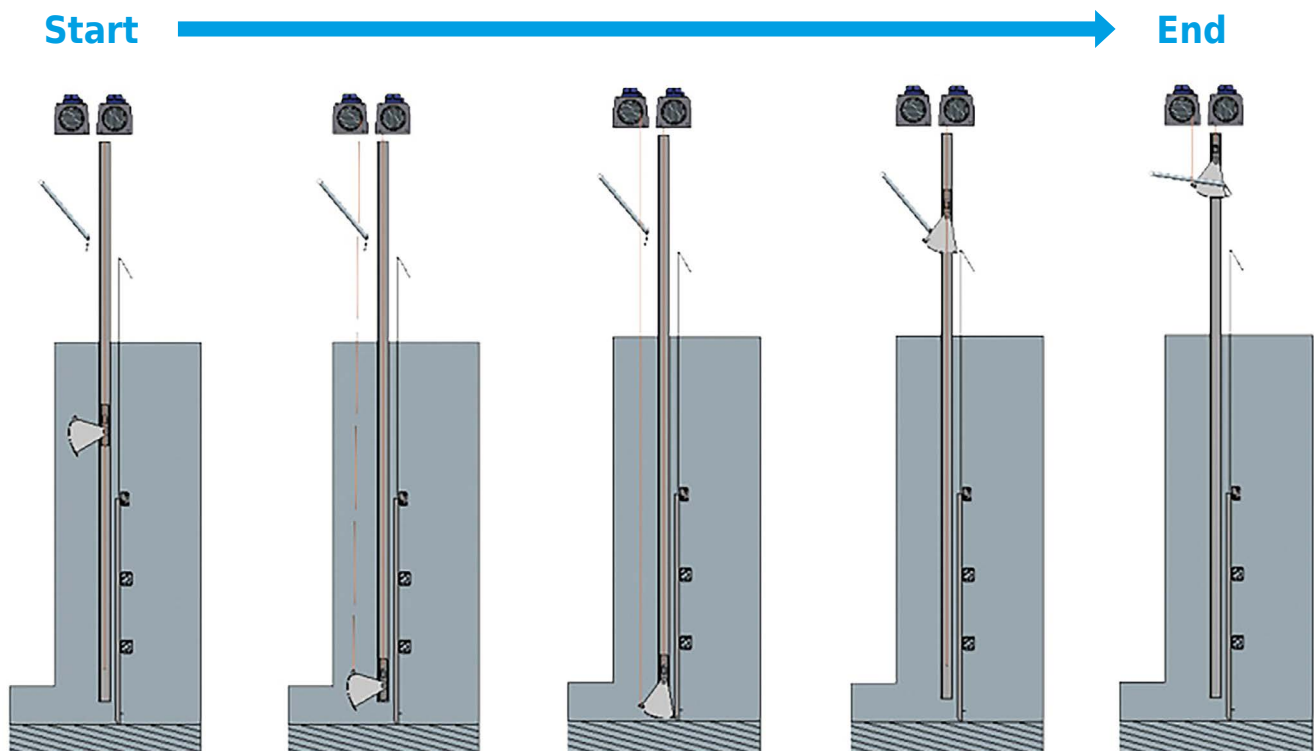

Functional principle of the HUBER Grab Screen TrashLift.

Use cases of the HUBER Grab Screen TrashLift

The HUBER Grab Screen TrashLift is used as a coarse or fine screen for the treatment of process/service water



Raw water for seawater desalination systems.

from river, sea and sea water, as well as for wastewater treatment in the following areas of application:



Removal of coarse and impurities in pump stations to protect downstream units, e.g. Qatar: 2 x TrashLift 17300 x 1220 with 50 mm gap width and 85° machine setup.



Process and cooling water for chemical plants and thermal power plants, e.g. in Germany: 1 x TrashLift 9425 x 2000 with 16 mm gap width and 90° machine setup.



Removal of coarse material from the inlet of large sewage treatment plants, e.g. China: 3 x TrashLift 16140 x 1700 with 20 mm gap width and 75° machine setup.

Huber Technology Inc.

1009 Airlie Parkway, Denver, NC 28037 USA

Phone: 704-949-1010 | info@hhusa.net

www.huber-technology.com

HUBER Grab Screen TrashLift

Subject to technical modification | 0.1 / 1 – 4.2024 – 4.2024