

Manhole cover SD4-RC4, attack-proof / security tested, weather-proof, round type

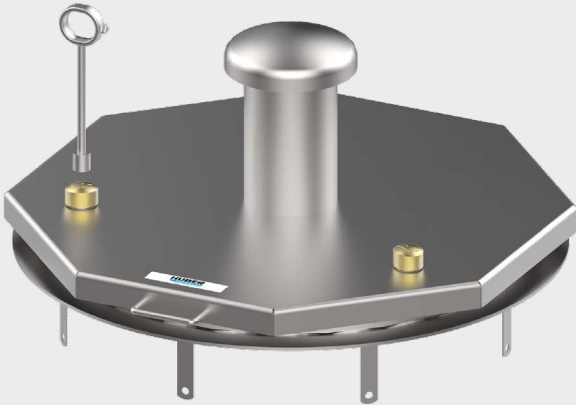

The figure shown here may contain special accessories.

Manhole cover, secure to prevent forced access, weatherproof, round in shape, completely made of 1.4307 (AISI 304 L) stainless steel.

Design based on DIN 1239:2018-4, security tested to resistance class RC4 (DIN EN 1627). According to requirements of DVGW W 1050 - Object protection for water supply structures. Suitable for use in Ex zone 1.

The cover consisting of a 4 mm thick stainless steel plate with a centrally raised profile, with stable concealed hinges, stainless steel gas assisted spring dampers, integrated arrestor which can only be undone by hand, with handle, with a replaceable circumferential, insect-proof and totally weatherproof rubber seal attached to the underside of the cover for low wear, including lock system with anti-drilling protection, as standard with hardened safety locks as recommended by criminal investigation departments and in accordance with the normative standards. The profile cylinders in accordance with DIN 18252 to be provided by the customer.

Connection for potential equalisation is provided.

The frame is made of bent profile, designed for bolted fixing with clips inside the manhole as lift locks.

Manhole cover and frame shielded arc-welded, acid-treated in a pickling bath and passivated.

Operating key included.

Options:

- ▶ 1.4404 (AISI 316 L) stainless steel
- ▶ Air vent DN 150, centrally welded
- ▶ Insulation of the cover, CFC-free
- ▶ Fixing material and foam rubber gasket
- ▶ Non-standard sizes
- ▶ Magnetic contact (cover open/shut indicator)
- ▶ Lacquer according to RAL colour chart
- ▶ Pollen filter or biofilter (for odour elimination) within the air vent
- ▶ Safety guard / antifall guard



Manhole cover SD4-RC4, attack-proof / security tested, weather-proof, round type

Subject to technical modification | Drawing no. 52310498, 11.2024

HUBER SE | Industriepark Erasbach A1 | D-92334 Berching | Telefon: +49 8462 201-0 | info@huber.de | www.huber.de

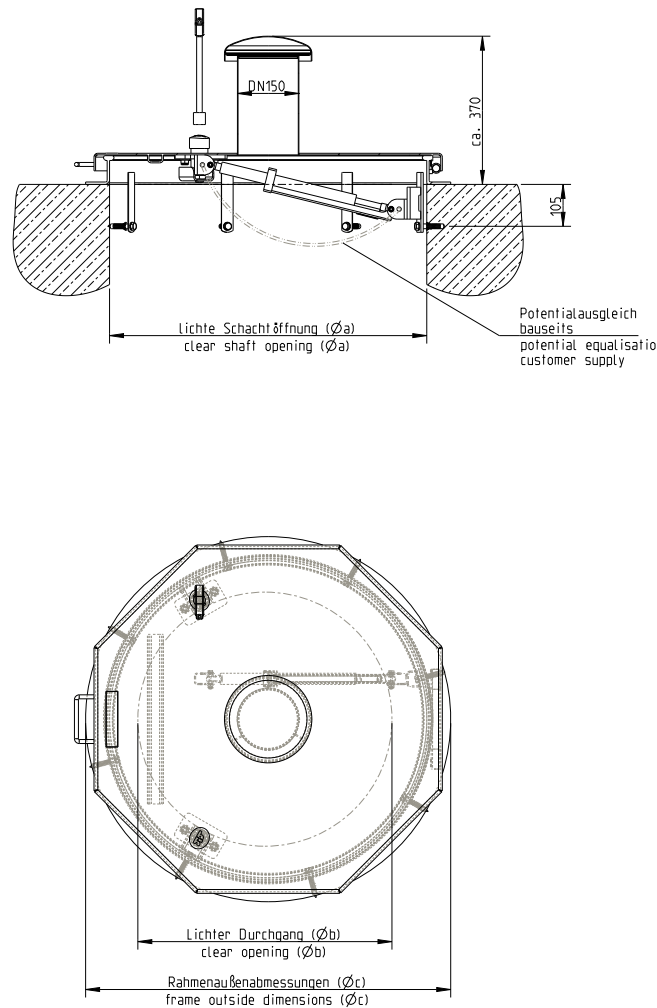

Model	Size $\varnothing a$	Order no.	Inside pass $\varnothing b$	Frame outside dimensions $\varnothing c$
Standard model	600	106/GRS-RC4 (1)	450	675
Standard model	800	108/GRS-RC4	620	875
Standard model	1000	101/GRS-RC4	820	1075
With air vent DN 150	600	106/GDRS-RC4 (1)	450	675
With air vent DN 150	800	108/GDRS-RC4	620	875
With air vent DN 150	1000	101/GDRS-RC4	820	1075
With insulation of cover, without FCKW	600	106/IRS-RC4 (1)	450	675
With insulation of cover, without FCKW	800	108/IRS-RC4	620	875
With insulation of cover, without FCKW	1000	101/IRS-RC4	820	1075
With air vent DN 150 and insulation of cover, without FCKW	600	106/IDRS-RC4 (1)	450	675
With air vent DN 150 and insulation of cover, without FCKW	800	108/IDRS-RC4	620	875
With air vent DN 150 and insulation of cover, without FCKW	1000	101/IDRS-RC4	820	1075

Ask for further dimensions. All measurements in mm.

(1) Note: According to German standards GUV-V C5 „Abwassertechnische Anlagen“ and DVGW Arbeitsblatt W122 „Abschlußbauwerke für Brunnen der Wassergewinnung“, the minimum clear width of entrance openings must be 0.8 m.



Manhole cover SD4-RC4, attack-proof / security tested, weather-proof, round type

Subject to technical modification | Drawing no. 52310498, 11.2024

HUBER SE | Industriepark Erasbach A1 | D-92334 Berching | Telefon: +49 8462 201-0 | info@huber.de | www.huber.de